

PROGRAMMA 400-ALU





## ALLUMINIO EN-AW 6060 - ALUMINUM ALLOY EN-AW 6060 - ALUMINIUM EN-AW 6060 - ALUMINIO EN-AW 6060

LA LEGA DI ALLUMINIO EN-AW 6060 È UNA LEGA A MEDIA RESISTENZA, HA UN'OTTIMA RESISTENZA ALLA CORROSIONE, OTTIMA SALDABILITÀ E BUONA RESISTENZA ALLE BASSE TEMPERATURE. È COMUNEMENTE USATA PER REALIZZARE ELEMENTI ANCHE CON FORMA COMPLESSA E RISULTA MOLTO BUONA NEI PROCESSI DI ANODIZZAZIONE.

THE ALUMINUM EN-AW 6060 ALLOY HAS AN EXCELLENT RESISTANCE TO CORROSION, TO LOW TEMPERATURES AND ALLOWS QUALITY WELDINGS. IN THE DESIGN WORLD IT IS COMMONLY USED TO CREATE COMPONENTS WITH COMPLEX SHAPES ALLOWING EXCELLENT QUALITY RESULTS COMPARED TO OTHER ALLOYS FOR ANODIZING TREATMENTS.

L'ALLIAGE D'ALUMINIUM EN-AW 6060 EST UN ALLIAGE POUVANT ÊTRE TRAITÉ THERMIQUEMENT DE RÉSISTANCE MOYENNE. IL PRÉSENTE UNE TRÈS BONNE RÉSISTANCE À LA CORROSION, UNE TRÈS BONNE SOUDABILITÉ ET UNE BONNE FORMABILITÉ À FROID. IL EST COURAMMENT UTILISÉ POUR LES SECTIONS COMPLEXES ET PRÉSENTE UNE TRÈS BONNE RÉPONSE AU PROCESSUS D'ANODISATION.

LA ALEACIÓN DE ALUMINIO EN-AW 6060 ES UNA ALEACIÓN QUE SE PUEDE TRATAR CON CALOR DE RESISTENCIA MEDIA. TIENE MUY BUENA RESISTENCIA A LA CORROSIÓN, MUY BUENA SOLDABILIDAD Y BUENA CONFORMABILIDAD EN FRÍO. SE USA COMÚNMENTE PARA CORTES TRANSVERSALES COMPLEJOS Y TIENE UNA RESPUESTA DE ANODIZACIÓN MUY BUENA.

## pba ANTI-MICROBIAL COATING **AMC**

I PRODOTTI IN ALLUMINIO HANNO PROPRIETÀ ANTIBATTERICHE NATURALI E UNA BUONA MANEGGEVOLEZZA PER LA PULIZIA. IL **RIVESTIMENTO ANTIMICROBICO pba (AMC)** È UNA FINITURA INNOVATIVA ALTAMENTE CONSIGLIATA PER TUTTE LE SITUAZIONI IN CUI L'IGIENE È ESTREMAMENTE IMPORTANTE NON SOLO PER LA DESTINAZIONE, MA ANCHE PER L'ALTA FREQUENTAZIONE COME GLI OSPEDALI E SPAZI PUBBLICI IN GENERE. AMC È DISPONIBILE PER TUTTE LE SERIE ALLUMINIO SU RICHIESTA.

IL **RIVESTIMENTO ANTIMICROBICO pba (AMC)** CONTIENE ADDITIVI SPECIALI CHE RENDONO LA SUPERFICIE PROTETTA DA BATTERI E MICRORGANISMI. I TEST DIMOSTRANO CHE SU SUPERFICI NON TRATTATE MICROBI E BATTERI POSSONO PROLIFERARE FACILMENTE MENTRE SULLE SUPERFICI TRATTATE LA PROLIFERAZIONE È PRATICAMENTE RIDOTTA A ZERO.

PRODUCTS IN ALUMINUM HAVE NATURAL ANTIBACTERIAL PROPERTIES AND A GOOD HANDLE ON CLEANLINESS. **pba ANTI-MICROBIAL COATING (AMC)** IS AN INNOVATIVE FINISHING HIGHLY RECOMMENDED FOR ALL SITUATIONS WHERE HYGIENE IS EXTREMELY IMPORTANT NOT ONLY FOR THE DESTINATION, BUT ALSO FOR THE HIGH ATTENDANCE LIKE HOSPITALS AND GENERALLY PUBLIC AND SPACES. AMC IS AVAILABLE FOR ALL THE ALUMINIUM SERIES ON REQUEST. THE **pba ANTI-MICROBIAL COATING (AMC)** SURFACE FINISHING CONTAINS SPECIAL ADDITIVES THAT MAKE THE SURFACE PROTECTED FROM BACTERIA AND MICROORGANISMS. THE TESTS SHOW THAT ON UNTREATED SURFACES THE MICROBES AND BACTERIA CAN EASILY PROLIFERATE WHILE ON THE TREATED SURFACES THE BACTERIAL PROLIFERATION IS PRACTICALLY ZEROED.

LES PRODUITS EN ALUMINIUM ONT DES PROPRIÉTÉS ANTI-MICROBIENNES NATURELLES ET PERMETTENT UNE PROPRIÉTÉ FACILE. LE **REVÊTEMENT ANTI-MICROBIEN pba (AMC)** EST UNE FINITION INNOVANTE HAUTEMENT RECOMMANDÉE POUR TOUTES LES ESPACES OÙ L'HYGIÈNE EST EXTRÊMEMENT IMPORTANTE PAS SEULEMENT POUR LE BUT MÊME, MAIS AUSSI POUR LA HAUTE FRÉQUENTATION COMME LES HÔPITAUX, BUREAUX, HÔTELS ET ESPACES PUBLICS GÉNÉRAUX. LE RAM EST DISPONIBLE POUR TOUS LES SÉRIES EN ALUMINIUM À LA DEMANDE. LE **REVÊTEMENT ANTI-MICROBIEN pba (AMC)** CONTIENT DES ADDITIFS SPÉCIAUX QUI PROTÈGENT LA SURFACE CONTRE LES BACTÉRIES ET LES MICROORGANISMES. LES TESTS MONTRENT QUE SUR LES SURFACES TRAITÉES LA PROLIFÉRATION BACTÉRIENNE EST RÉDUITE PRATIQUEMENT À ZÉRO.

LOS PRODUCTOS DE ALUMINIO TIENEN PROPIEDADES ANTIBACTERIANAS NATURALES Y PERMITEN LIMPIAR FÁCILMENTE. EL **RECUBRIMIENTO ANTI-MICROBIANO pba (AMC)** ES UN ACABADO INNOVADOR RECOMENDADO PARA TODAS LAS SITUACIONES EN LAS QUE LA HIGIENE ES MUY IMPORTANTE NO SOLO PARA EL AMBIENTE, SINO TAMBIÉN PARA LA ALTA PRESENCIA, COMO HOSPITALES, OFICINAS, HOTELES Y EN GENERAL ESPACIOS PÚBLICOS. EL ACABADO AMC ESTÁ DISPONIBLE PARA LAS SERIES DE ALUMINIO BAJO PETICIÓN.

EL **RECUBRIMIENTO ANTI-MICROBIANO pba (AMC)** CONTIENE ADITIVOS ESPECIALES QUE HACEN PROTEGER LA SUPERFICIE CONTRA LAS BACTERIAS Y LOS MICROORGANISMOS. LAS PRUEBAS HAN DEMOSTRADO QUE LA PROLIFERACIÓN DE BACTERIAS SOBRE LAS SUPERFICIES TRATADAS ES REDUCIDA A CERO.

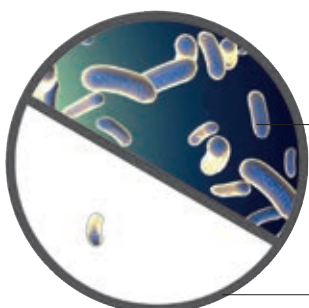





MULTI-RESISTANT  
PATHOGENS DEVELOP  
WITHOUT pba AMC

pba AMC REDUCES  
PATHOGENS BY  
ABOUT 99.99%

**STANDARD**

**.70  
LIGHT BRONZE**

-  **RAIL**  
Aluminum anodized  
Light Bronze
-  **ACCESSORIES**  
Polyamide 6 Grey
-  **SUPPORT AND BENDS**  
Powder-coated  
Aluminum Alloy and Zamak Grey
-  **AMC .A0**  
Transparent  
Light Bronze

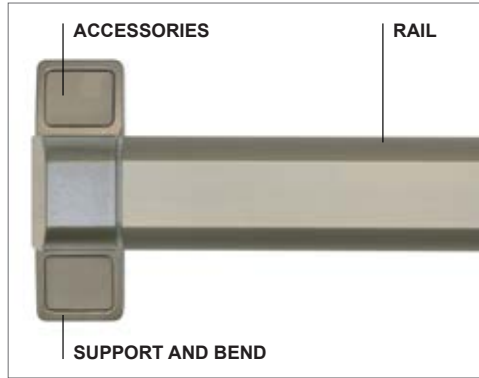





**.70  
GREY**

-  **ACCESSORIES**  
Polyamide 6



**.71  
SILVER**

-  **RAIL**  
Aluminum anodized silver
-  **ACCESSORIES**  
Polyamide 6 White
-  **SUPPORT AND BENDS**  
Powder-coated  
Aluminum Alloy and Zamak White
-  **AMC .A2**  
Transparent  
Silver

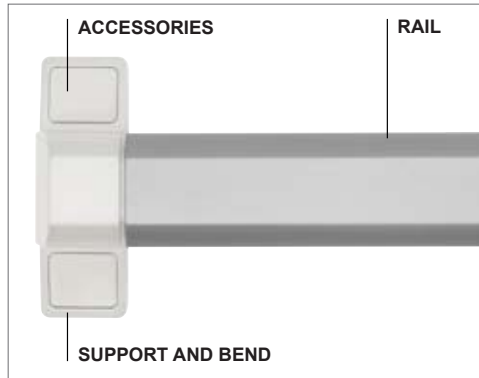



**.71  
WHITE**

-  **ACCESSORIES**  
Polyamide 6



**UPON REQUEST - ON MINIMUM LOT TO BE AGREED**

**.79  
DARK BRONZE**

-  **RAIL**  
Aluminum anodized
- SUPPORT AND BENDS**  
Powder-coated
- ACCESSORIES**  
Polyamide 6
-  **AMC .A9**  
Transparent  
Dark Bronze  
On minimum lot to be agreed

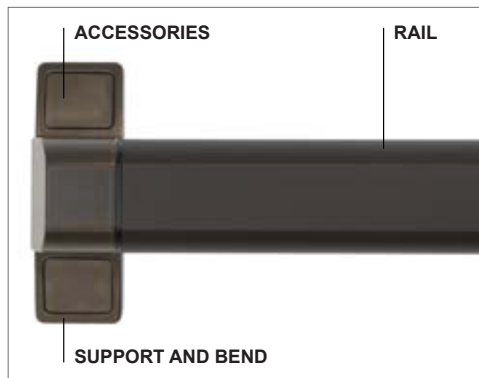



**.17  
ANTHRACITE**

-  **ACCESSORIES**  
Polyamide 6



**.73  
BLACK**

-  **RAIL**  
Aluminum anodized
- SUPPORT AND BENDS**  
Powder-coated
- ACCESSORIES**  
Polyamide 6
-  **AMC .A3**  
Transparent  
Black  
On minimum lot to be agreed

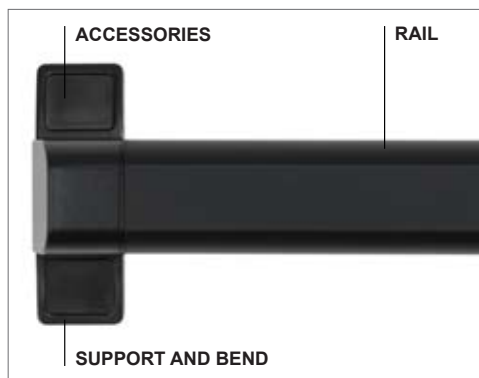

**.10  
BLACK**

-  **ACCESSORIES**  
Polyamide 6



SOSTEGNI DI SICUREZZA  
SAFETY SUPPORTS  
BARRES D'APPUI  
ASIDEROS

Page 112



AUSILI DI SICUREZZA RIBALTABILI  
LIFT-UP SAFETY SUPPORTS  
BARRES D'APPUI RELEVABLES  
ASIDEROS ABATIBLES

Page 120

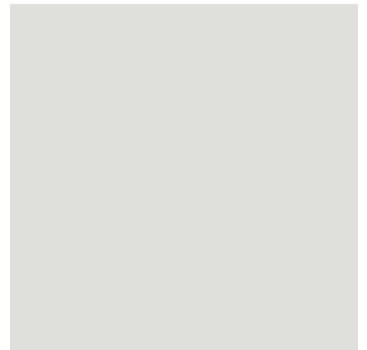

SEGGIOLINI  
SEATS  
SIÈGES  
ASIENTOS

Page 124



ACCESSORI BAGNO  
BATHROOM ACCESSORIES  
ACCESSOIRES DE BAIN  
ACCESORIOS DE BAÑO

Page 128



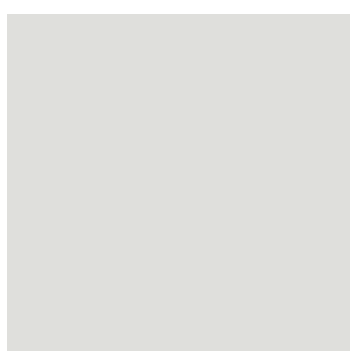
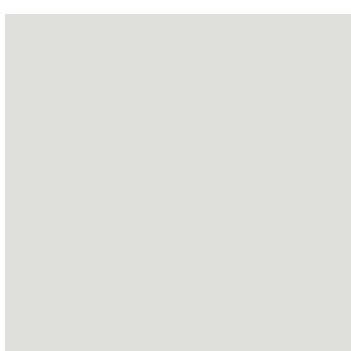
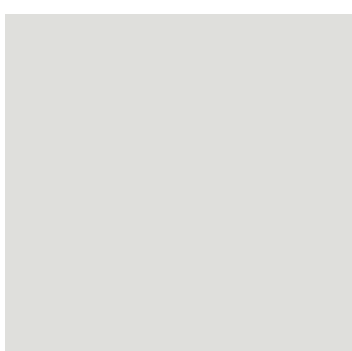
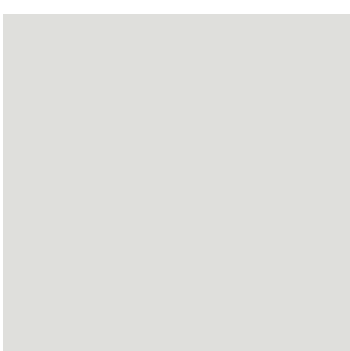
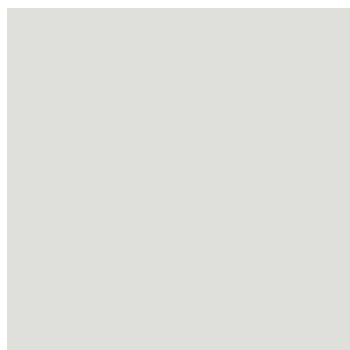
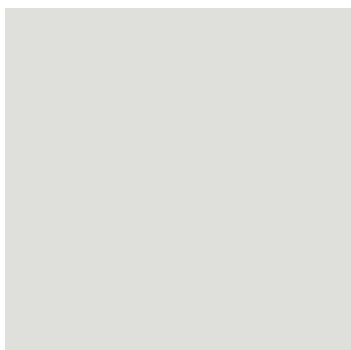
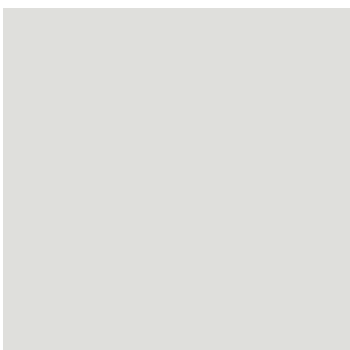
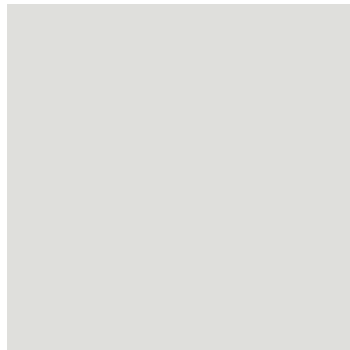
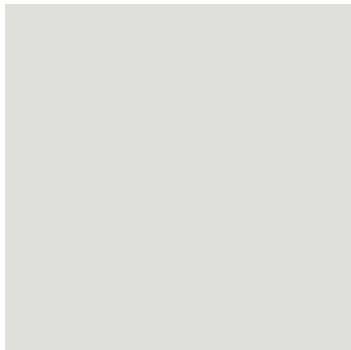
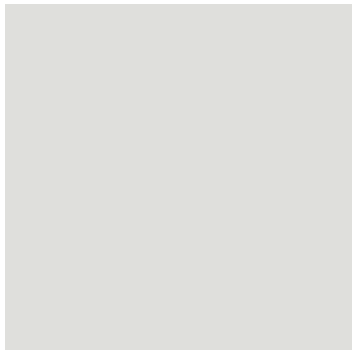
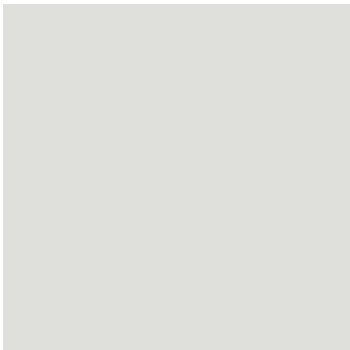
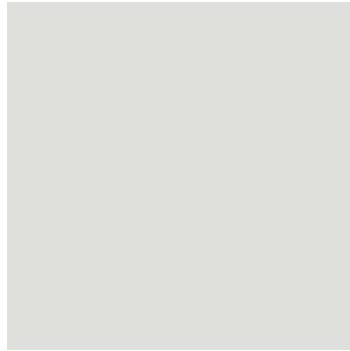
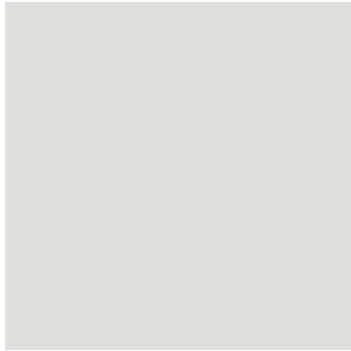
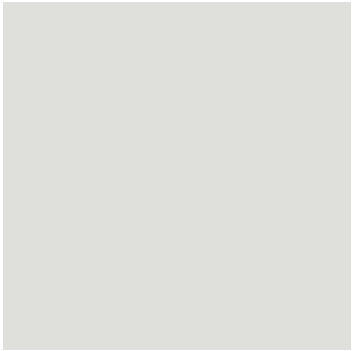
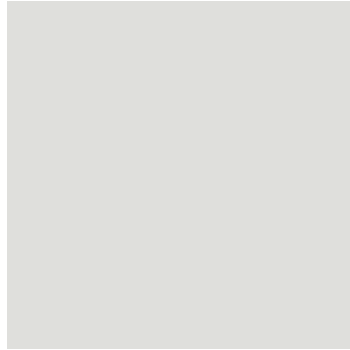
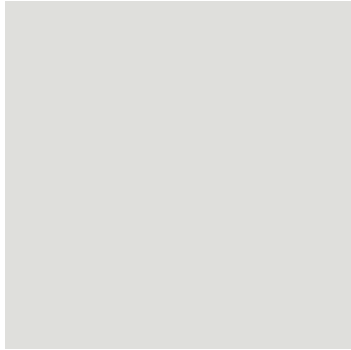
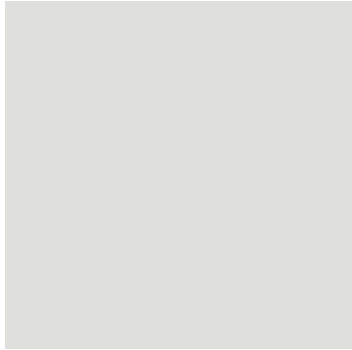
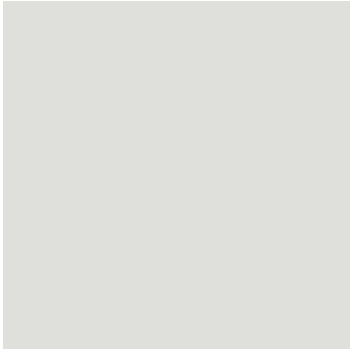





◆ RIGHT

ART.	◆	A	B
▲ 4CA.422.0000 .xx .x		220 (277)*	520 (577)*
🔧 4CA.22J.0000 .xx .x			
🔧 4CA.22Y.0000 .xx .x			
▲ 4CA.422.000M .xx .x		300 (357)*	520 (577)*
🔧 4CA.22J.000M .xx .x			
🔧 4CA.22Y.000M .xx .x			
▲ 4CA.422.000L .xx .x		320 (377)*	720 (777)*
🔧 4CA.22J.000L .xx .x			
🔧 4CA.22Y.000L .xx .x			
4CA.422.5075 .xx .x		500 (557)*	750 (807)*
🔧 4CA.22J.5075 .xx .x			
🔧 4CA.22Y.5075 .xx .x			

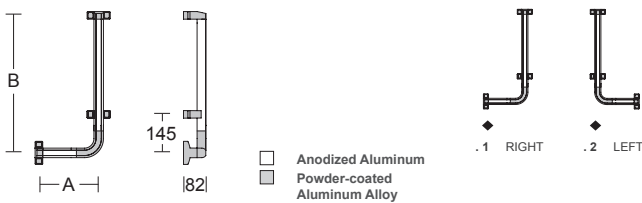

□ Anodized Aluminum  
 ■ Powder-coated Aluminum Alloy

ART.	◆	A	B
▲ 4CA.422.00LA .xx .x		400 (457)*	1160 (1217)*
🔧 4CA.22J.00LA .xx .x			
4CA.422.9999 .xx .x	⊙		⊙
🔧 4CA.22J.9999 .xx .x			

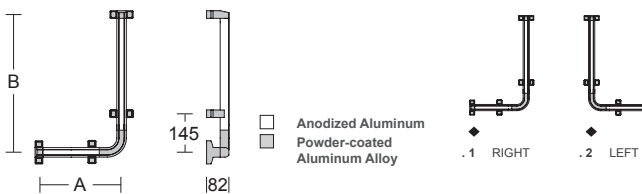

□ Anodized Aluminum  
 ■ Powder-coated Aluminum Alloy

- Sostegno di sicurezza a "L"
- "L"-shaped safety support
- Barre d'appui forme à "L"
- Asidero en "L"



.XX FINISH	.70	.71	.A0 AMC Transparent Light Bronze	.A2 AMC Transparent Silver



ART.	A	B	
▲ 4CA.433.0000 .xx	1570 (1598)*	820 (877)*	⚠
🔧 4CA.33J.0000 .xx			⚠
🔧 4CA.33Y.0000 .xx			⚠
4CA.433.000L .xx	1570 (1598)*	1160 (1215)*	
🔧 4CA.33J.000L .xx			
🔧 4CA.33Y.000L .xx			
4CA.433.9999 .xx	⊙	⊙	
🔧 4CA.33J.9999 .xx			
🔧 4CA.33Y.9999 .xx			

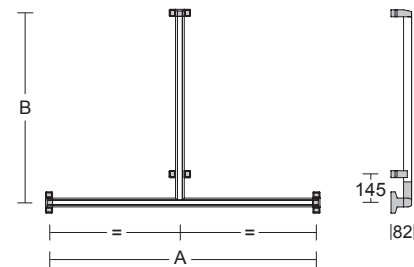

□ Anodized Aluminum  
 ■ Powder-coated Aluminum Alloy

- Sostegno di sicurezza a "T"
- "T"-shaped safety support
- Barre d'appui forme à "T"
- Asidero en "T"



◆	.1 DESTRO RIGHT DROITE DERECHA	.2 SINISTRO LEFT GAUCHE IZQUIERDA





ART.	◆	A	B	C	D
▲ 4CA.424.0000 .xx .x		660 (674)*	660 (702)*	820 (877)*	498
🌀 4CA.24J.0000 .xx .x					
▲ 4CA.424.000L .xx .x		760 (774)*	400 (442)*	1160 (1217)*	-
🌀 4CA.24J.000L .xx .x					
▲ 4CA.424.00LA .xx .x		760 (774)*	760 (802)*	1160 (1217)*	598
🌀 4CA.24J.00LA .xx .x					
4CA.424.9999 .xx .x	Ⓢ				
🌀 4CA.24J.9999 .xx .x					

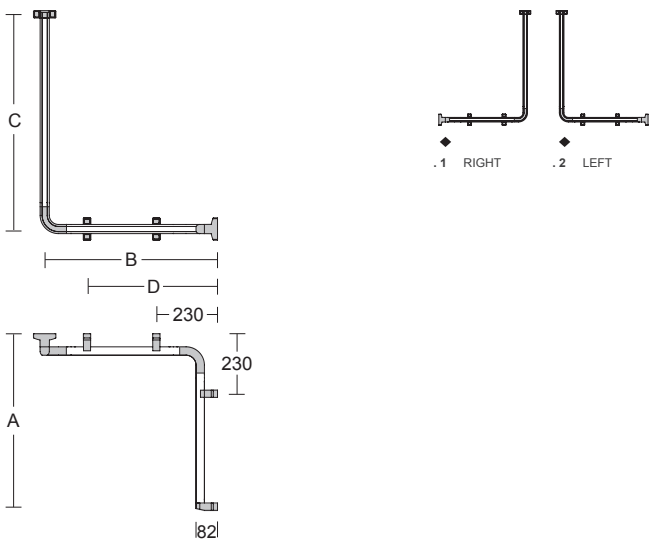

□ Anodized Aluminum  
 ■ Powder-coated Aluminum Alloy

- Sostegno di sicurezza ad angolo con impugnatura verticale  
 - Corner safety support with shower head rail  
 - Barre d'appui à coin avec barre de douche  
 - Asidero en ángulo con empuñadura vertical



.XX FINISH



.A0  
 AMC  
 Transparent  
 Light Bronze

.A2  
 AMC  
 Transparent  
 Silver



ART.	◆	A	B	C
▲ 4CA.443.000B .xx .x		760 (774)*	760 (774)*	1160 (1217)*
🌀 4CA.43J.000B .xx .x				
▲ 4CA.443.00BL .xx .x		760 (774)*	1184 (1198)*	1160 (1217)*
🌀 4CA.43J.00BL .xx .x				
4CA.443.00BM .xx .x		920 (934)*	920 (934)*	1160 (1217)*
🌀 4CA.43J.00BM .xx .x				
4CA.443.999B .xx .x	Ⓢ			
🌀 4CA.43J.999B .xx .x				

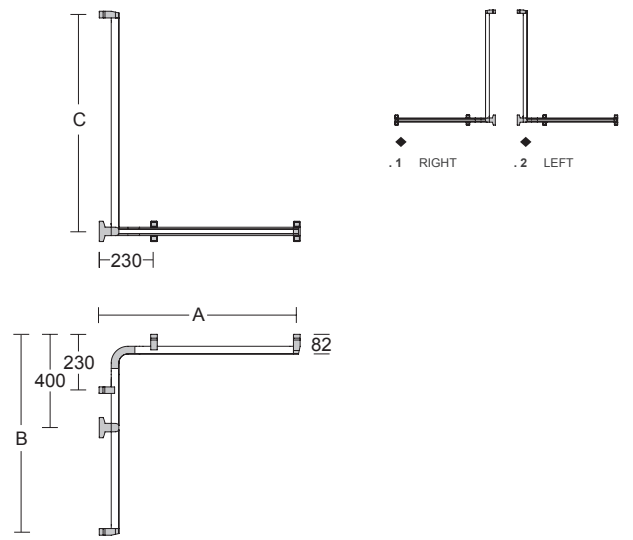

□ Anodized Aluminum  
 ■ Powder-coated Aluminum Alloy

- Sostegno di sicurezza ad angolo con impugnatura verticale  
 - Corner safety support with shower head rail  
 - Barre d'appui à coin avec barre de douche  
 - Asidero en ángulo con empuñadura vertical



◆  
 .1 DESTRO RIGHT DROITE DERECHA  
 .2 SINISTRO LEFT GAUCHE IZQUIERDA



ART.	A
▲ 4CA.487.0000 .xx	570 (598)*
▲ 4CA.487.000A .xx	770 (798)*
▲ 4CA.487.000B .xx	970 (998)*
▲ 4CA.487.000C .xx	1170 (1198)*
4CA.487.9999 .xx	Ⓢ

ART.	A	B
4CA.487.00RD .xx	140*	93*

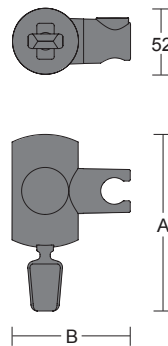
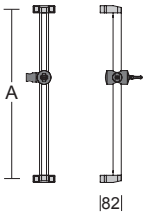

- Anodized Aluminum
- Powder-coated Aluminum Alloy
- Polyamide 6

- Polyamide 6

- Sostegno di sicurezza con reggisoffione
- Fixed safety support with shower head holder
- Barre d'appui fixe avec curseur de douchette
- Asidero con soporte para ducha regulable en altura



- Reggisoffione girevole con attacco conico universale a scorrimento compatibile con sostegni di sicurezza del PROGRAMMA ALU
- Rotating shower head holder with universal sliding tapered connection compatible with all safety supports of the PROGRAMMA ALU
- Curseur de douche rabatable avec élément de fixation mobile et conique universel compatible avec les barres d'appui du PROGRAMMA ALU
- Soporte ducha giratorio con base cónica universal deslizable compatible con todos los asideros del PROGRAMA ALU

.XX FINISH





ART.	A
▲ 4CA.440.0000 . xx	370 (398)*
▲ 4CA.40Y.0000 . xx	
▲ 4CA.440.000A . xx	570 (598)*
▲ 4CA.40Y.000A . xx	
▲ 4CA.440.000B . xx	770 (798)*
▲ 4CA.40Y.000B . xx	
▶ ▲ 4CA.440.000C . xx	970 (998)*
▲ 4CA.40Y.000C . xx	
▲ 4CA.440.000Z . xx	300 (328)*
▲ 4CA.40Y.000Z . xx	
4CA.440.9999 . xx	
4CA.40Y.9999 . xx	



- Anodized Aluminum
- Powder-coated Aluminum Alloy

- Sostegno di sicurezza orizzontale
- Horizontal safety support
- Barre d'appui horizontale
- Asidero horizontal



.XX FINISH

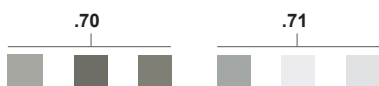

.A0  
AMC  
Transparent  
Light Bronze

.A2  
AMC  
Transparent  
Silver



ART.	A
▲ 4CA.423.000B . xx	1370 (1398)*
▶ ▲ 4CA.423.00BL . xx	1570 (1598)*
4CA.423.999B . xx	

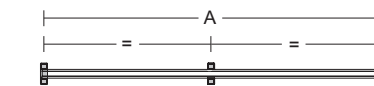

- Anodized Aluminum
- Powder-coated Aluminum Alloy

- Sostegno di sicurezza orizzontale con supporto intermedio
- Horizontal safety support with intermediate wall support
- Barre d'appui horizontale avec support intermédiaire
- Asidero horizontal con soporte intermedio





◆ LEFT

ART.	A	
▲ 4CA.442.0000 . xx	760 (774)*	
▲ 4CA.442.000M . xx	960 (974)*	
▶ ▲ 4CA.442.000L . xx	1160 (1174)*	⚠
4CA.442.9999 . xx		♻️

ART.	◆	A	B
▲ 4CA.427.0000 . xx . x		500 (514)*	300 (314)*
🔧 4CA.27Y.0000 . xx . x			

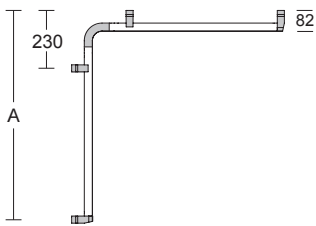
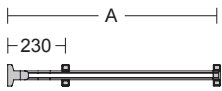

- Anodized Aluminum
- Powder-coated Aluminum Alloy

- Sostegno di sicurezza ad angolo simmetrico
- Symmetric corner safety support
- Barre d'appui à coin symétrique
- Asidero en ángulo simétrico

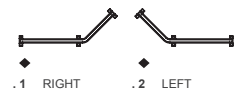
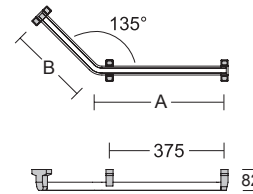

- Anodized Aluminum
- Powder-coated Aluminum Alloy

- Sostegno di sicurezza fisso aperto
- Open fixed safety support
- Barre d'appui fixe coudée
- Asidero fijo en ángulo



.XX FINISH

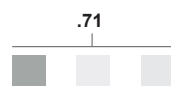

.A0  
AMC  
Transparent  
Light Bronze

.A2  
AMC  
Transparent  
Silver

- ◆ .1 DESTRO RIGHT DROITE DERECHA
- .2 SINISTRO LEFT GAUCHE IZQUIERDA



ART.	A
▲ 4CA.441.000P . xx	600*
▲ 4CA.441.00PL . xx	700*
▲ 4CA.441.0PLL . xx	850*

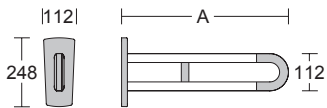

- Anodized Aluminum
- Powder-coated Aluminum Alloy

- Sostegno di sicurezza fisso su piastra
- Safety support fixed on plate
- Barre d'appui fixe sur plaque
- Asidero fijo sobre placa



.XX FINISH

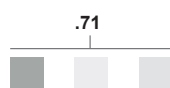
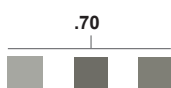

.A0  
AMC  
Transparent  
Light Bronze

.A2  
AMC  
Transparent  
Silver

.XX FINISH







ART.	A
▲ 4CA.445.000T . xx	600*
4CA.45Y.000T . xx	
4CA.45K.000T . xx	
▲ 4CA.445.0000 . xx	700*
4CA.45Y.0000 . xx	
4CA.45K.0000 . xx	
▲ 4CA.445.000L . xx	850*
4CA.45Y.000L . xx	
4CA.45K.000L . xx	

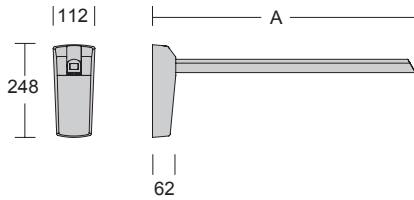

■ Powder-coated Aluminum Alloy

- Sostegno di sicurezza ribaltabile
- Lift-up safety support
- Barre d'appui rilevabile
- Asidero abatible

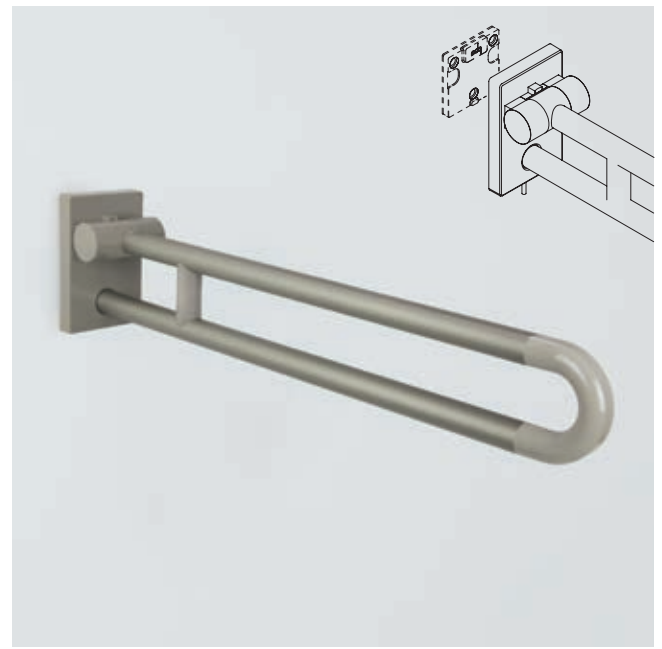

ART.	A
4CA.445.00CT . xx	600*
4CA.445.000C . xx	700*
4CA.445.00CL . xx	850*

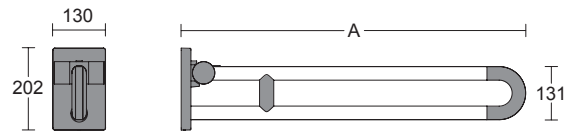
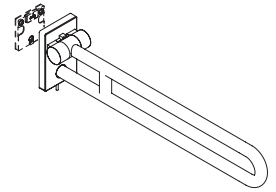

□ Anodized Aluminum  
■ Polyamide 6

- Sostegno di sicurezza ribaltabile estraibile
- Extractable lift-up safety support
- Barre d'appui rilevabile amovibile
- Asidero abatible y extraíble



.XX FINISH



.71



.A0

AMC  
Transparent  
Light Bronze

.A2

AMC  
Transparent  
Silver





ART.  
4CN.445.0CPM . 00

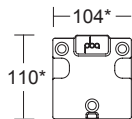

- Placca a muro per sostegno di sicurezza ribaltabile estraibile
- Wall plate for extractable lift-up safety support
- Plaque murale pour barre d'appui relevable amovible
- Placa en pared del asidero abatible y extraíble



ART.  
4CN.445.0CCP . xx

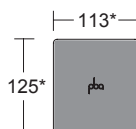

- Coperchio per placca a muro del sostegno di sicurezza ribaltabile estraibile
- Cover for wall plate of the extractable Lift-up safety support
- Couverture pour la plaque murale de la barre d'appui relevable amovible
- Tapa embellecedora para la placa en pared del asidero para baño abatible y extraíble

■ Polyamide 6

.XX FINISH



.XX FINISH







ART.	A	B
▲ 4CA.451.000B .xx	378*	400*
■ 4CA.51K.000B .xx	378*	400*

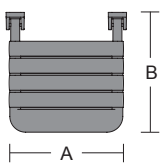
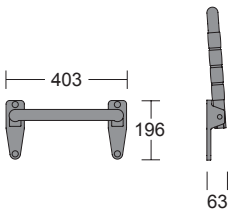

■ Polyamide 6

- Seggiolino ribaltabile
- Lift-up shower seat
- Siège relevable
- Asiento abatible



.XX FINISH



ART.	A	B	C	D
4CA.450.00CM .xx	400*	510*	560*	316
4CA.450.0CML .xx	400*	510*	560*	386

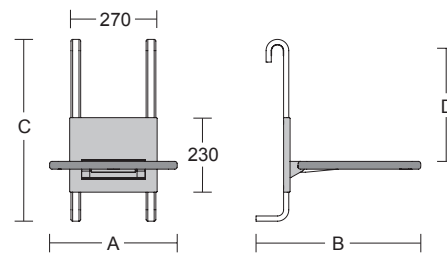

- Anodized Aluminum
- Powder-coated Aluminum Alloy
- Polyurethane

- Seggiolino agganciabile e ribaltabile
- Lift-up suspended seat
- Siège à suspendre et relevable
- Asiento suspendido y abatible





ART.	A	B
4CN.447.00CM . xx	400*	415*
4CN.47K.00CM . xx	400*	415*

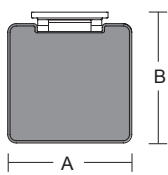
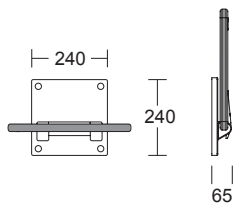

- Polyamide 6
- Polyurethane

- Seggiolino ribaltabile
- Lift-up shower seat
- Siège relevable
- Asiento abatible



.XX FINISH



ART.	A	B	C
4CA.434.0000 . xx	490 (520)*	210*	200*
4CA.434.000L . xx	700 (730)*	210*	200*

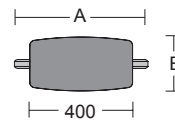

ART.	A	B	C
4CA.434.000R . xx	467 (496)* - 587 (616)*	210*	200*

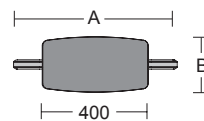

- Anodized Aluminum
- Powder-coated Aluminum Alloy
- Polyurethane

- Appoggiaschiena da WC
- WC Backrest
- Appui dos pour WC
- Respaldo de WC





.XX FINISH







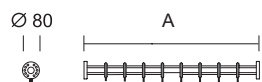

ART.	A	
4CA.429.0000 .xx	800*	8
4CA.429.000A .xx	900*	9
4CA.429.000B .xx	1000*	10
4CA.429.000C .xx	1100*	11
4CA.429.000D .xx	1200*	12
4CA.429.000E .xx	1300*	13
4CA.429.9999 .xx		



- Anodized Aluminum
- Polyamid 6

- Reggitenda dritto
- Straight shower curtain rail
- Barre de rideau de douche droit
- Barra de cortina de ducha recta



ART.	A	B	
4CA.436.0000 .xx	800 (815)*	800 (815)*	16
4CA.436.9999 .xx			

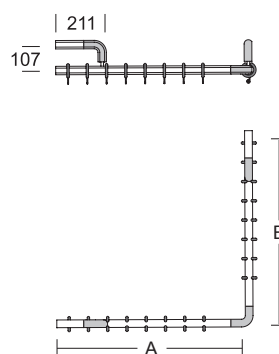

- Anodized Aluminum
- Powder-coated Aluminum Alloy
- Polyamid 6

- Reggitenda angolare con due supporti a muro
- Corner shower curtain rail with two wall supports
- Barre de rideau de douche à coin avec deux supports murales
- Barra de cortina de ducha en ángulo con dos soportes en pared

.XX FINISH

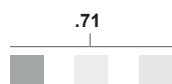
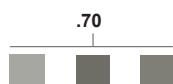

**.A0**  
AMC  
Transparent  
Light Bronze

**.A2**  
AMC  
Transparent  
Silver





ART.	A	B	C	
4CA.436.000B .xx	800 (815)*	800 (815)*	440 (458)*	16
4CA.436.000BA .xx	900 (915)*	900 (915)*	440 (458)*	18
4CA.436.000BB .xx	1000 (1015)*	1000 (1015)*	440 (458)*	20
4CA.436.000BC .xx	1200 (1215)*	1200 (1215)*	440 (458)*	24
4CA.436.000BD .xx	1500 (1515)*	1500 (1515)*	440 (458)*	30
4CA.436.999B .xx				

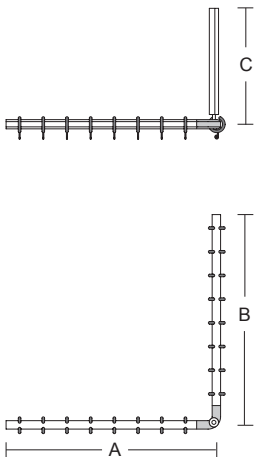

- Anodized Aluminum
- Powder-coated Aluminum Alloy
- Polyamide 6

- Reggitenda angolare con supporto a soffitto
- Corner shower curtain rail with ceiling support
- Barre de rideau de douche à coin avec support plafond
- Barra de cortina de ducha en ángulo con soporte de techo



ART.	A	B	C	
4CA.437.0000 .xx	800 (815)*	800 (830)*	440 (458)*	24
4CA.437.000A .xx	1000 (1015)*	1000 (1030)*	440 (458)*	30
4CA.437.9999 .xx				

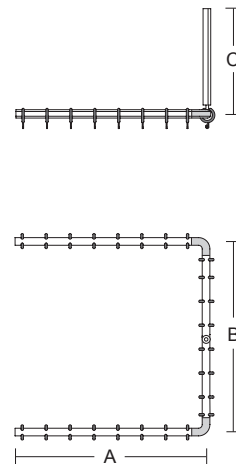

- Anodized Aluminum
- Powder-coated Aluminum Alloy
- Polyamide 6

- Reggitenda su tre lati con supporto a soffitto
- Three-sided shower curtain rail with ceiling support
- Barre de rideau de douche sur trois côtés avec support plafond
- Barra de cortina de ducha en "U" con soporte de techo

.XX FINISH

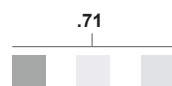
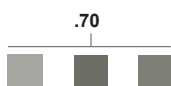

.A0  
AMC  
Transparent  
Light Bronze

.A2  
AMC  
Transparent  
Silver



ART.	L	H	
<b>4CN.0SC.000B.01</b>	1200	2000	Art. 4CA.429.0000 .xx
			4CA.429.000A .xx
			4CA.429.000B .xx
			4CA.436.0000 .xx*
			4CA.436.000B .xx*
			4CA.436.00BA .xx*
<b>4CN.0SC.000C.01</b>	1800	2000	Art. 4CA.429.000C .xx
			4CA.429.000D .xx
			4CA.429.000E .xx
			4CA.436.00BC .xx*
			4CA.436.00BD .xx*
			4CA.437.0000 .xx*
			4CA.437.000A .xx*

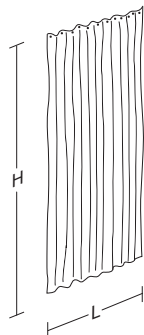

- Tenda ignifuga per doccia
- Fireproof shower curtain
- Rideau de douche ignifuge
- Cortina de ducha ignifuga



ART.	L	H	
<b>4CN.0SC.00BE.01</b>	1200	2000	Art. 4CA.429.0000 .xx
			4CA.429.000A .xx
<b>4CN.0SC.00FE.01</b>	1500	2000	Art. 4CA.429.000B .xx
			4CA.429.000C .xx
			4CA.436.00BC .xx*
			4CA.437.0000 .xx*
<b>4CN.0SC.00CE.01</b>	1800	2000	Art. 4CA.429.000D .xx
			4CA.429.000E .xx
			4CA.436.00BD .xx*
			4CA.437.000A .xx*
<b>4CN.0SC.00DE.01</b>	2000	2000	Art. 4CA.436.0000 .xx
			4CA.436.000B .xx
<b>4CN.0SC.00EE.01</b>	2400	2000	Art. 4CA.436.00BA .xx
			4CA.436.00BB .xx

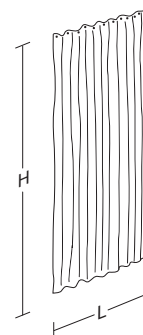

- Tenda impermeabile per doccia
- Waterproof shower curtain
- Rideau de douche imperméable
- Cortina de ducha impermeable



ART.	A	B	C
4CA.490.00QR .xx	600*	700*	15
4CA.490.00AR .xx	600*	1100*	15

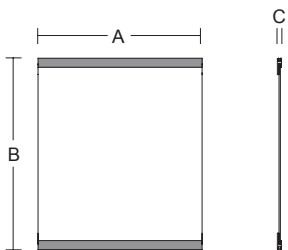

■ Anodized Aluminum

- Specchio fisso con cornice
- Fixed mirror with frame
- Miroir fixe avec cadre
- Espejo fijo con marco



ART.	A	B	C	$\alpha$
4CA.470.0000 .xx	600*	540*	150*	14°
4CA.470.000Q .xx	600*	690*	190*	14°

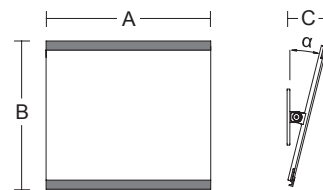

■ Anodized Aluminum

- Specchio orientabile con cornice
- Adjustable mirror with frame
- Miroir orientable avec cadre
- Espejo orientable con marco

.XX FINISH

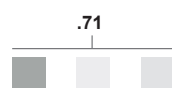
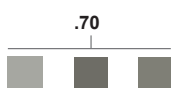

.A0  
AMC  
Transparent  
Light Bronze

.A2  
AMC  
Transparent  
Silver



ART.	A	B	C
4CA.001.0000.00	600*	800*	54,5

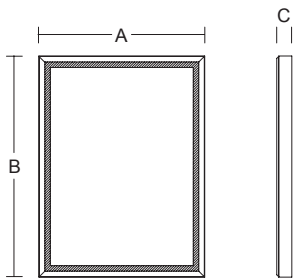

Aluminum Black

- Specchio fisso con cornice alluminio e luce led integrata
- Fixed mirror with aluminium frame and integrated led light
- Miroir fixe avec cadre en aluminium et éclairage led intégré
- Espejo fijo con marco de aluminio y luz led integrada

.XX FINISH

.00



ART.	A	B	C	$\alpha$
4CA.002.0000.00	600*	800*	40*	11°

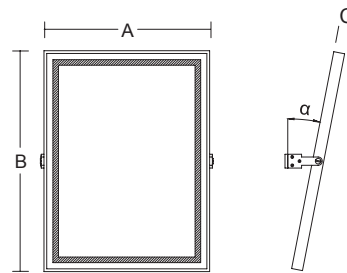

Aluminum Black

- Specchio orientabile con cornice alluminio e luce led integrata
- Adjustable mirror with aluminium frame and integrated led light
- Miroir orientable avec cadre en aluminium et éclairage led intégré
- Espejo orientable con marco de aluminio y luz led integrada



ART.	A	B	C	$\alpha$
4CA.471.0000.00	600*	500*	160*	18°
4CA.471.000Q.00	600*	650*	210*	18°

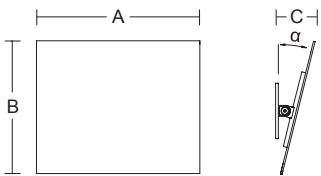

- Specchio orientabile senza cornice
- Adjustable mirror without frame
- Miroir orientable sans cadre
- Espejo orientable sin marco



ART.	A	B	C
4CN.490.000R . xx	600*	500	550*
4CN.490.00QR . xx	600*	650	700*
4CN.490.00AR . xx	600*	950	1000*

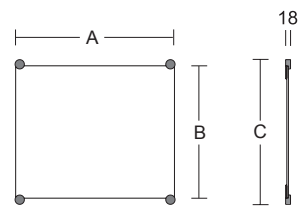

■ Polyamide 6

- Specchio fisso
- Fixed mirror
- Miroir fixe
- Espejo fijo

.XX FINISH

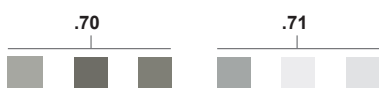



ART.	A	B
4CN.490.0WHR .xx	38	64

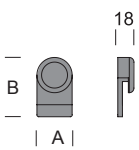

■ Polyamide 6

- Kit pinza reggispecchio per specchio fisso (4 pezzi)
- Kit mirror-holder supports for fixed mirror (4 pieces)
- Jeu supports porte-miroir pour miroir fixe (4 pièces)
- Juego pinza para anclar el espejo fijo (4 piezas)

.XX FINISH



ART.	A	B
4CN.407.0TUA .xx	405*	61*

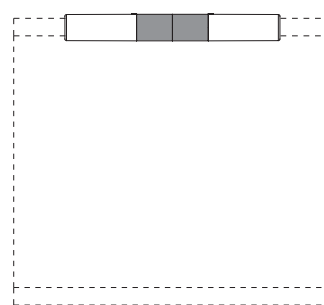
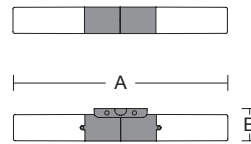

■ Polyamide 6

- Lampada da applicare su specchi con cornice.  
IP 54 con Art. 4CN.0IP.0068.00
- Lamp for mirrors with frame.  
IP 54 with Art. 4CN.0IP.0068.00
- Lampe pour miroirs avec cadre.  
IP 54 avec Art. 4CN.0IP.0068.00
- Aplique para espejos con marco  
IP 54 con Art. 4CN.0IP.0068.00

CE  
IP 54



ART.	A	B
4CN.407.00TU .xx	405*	84*

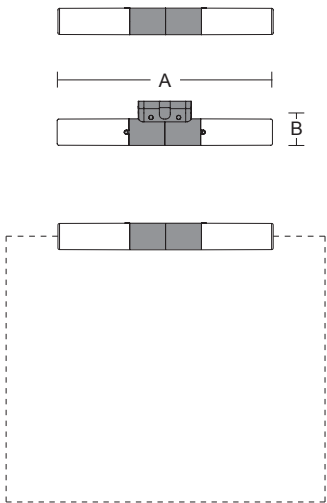

■ Polyamide 6

- Lampada da applicare su specchi senza cornice.  
IP 54 con Art. 4CN.0IP.0068.00
- Lamp for mirrors without frame.  
IP 54 with Art. 4CN.0IP.0068.00
- Lampe pour miroirs sans cadre.  
IP 54 avec Art. 4CN.0IP.0068.00
- Aplique para espejos sin marco  
IP 54 con Art. 4CN.0IP.0068.00

CE  
IP 54

.XX FINISH



ART.	A	B
4CN.407.0TUR .xx	405*	77*

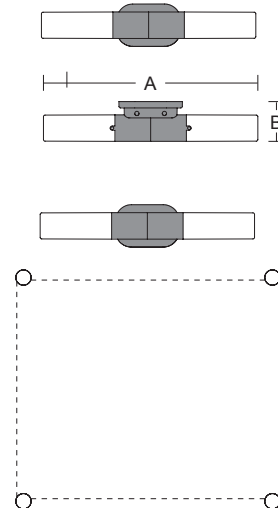

■ Polyamide 6

- Lampada da fissare a parete.  
IP 54 con Art. 4CN.0IP.0068.00
- Wall lamp for mirror.  
IP 54 with Art. 4CN.0IP.0068.00
- Lampe de mur pour miroir.  
IP 54 avec Art. 4CN.0IP.0068.00
- Aplique con fijación en pared  
IP 54 con Art. 4CN.0IP.0068.00

CE  
IP 54



ART.	A	B
4CA.484.00AL .xx	600 (630)*	141* alluminio - aluminium - aluminium - aluminium
4CA.484.99AL .xx		141* alluminio - aluminium - aluminium - aluminium

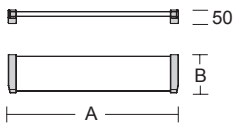

ART.	A	B
4CA.484.0BAL .xx	650 (680)*	150* alluminio - aluminium - aluminium - aluminium

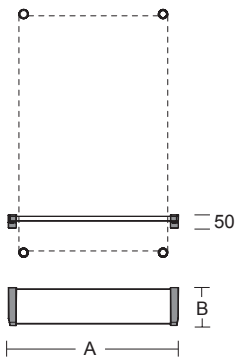

Anodized Aluminum  
 Polyamide 6

- Mensola con ripiano in alluminio
- Aluminium bathroom shelf
- Tablette en aluminium
- Estante con repisa en aluminio



ART.	A	B
4CA.485.0IAL .xx	600 (630)*	141* aluminium
4CA.485.9IAL .xx		141* aluminium

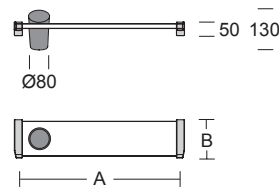

ART.	A	B
4CA.485.IBAL .xx	650 (680)*	150* aluminium

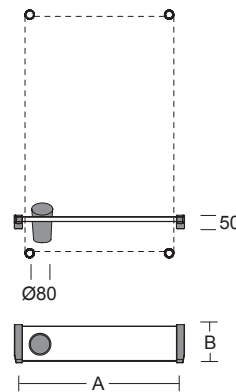

Anodized Aluminum  
 Polyamide 6

- Mensola con ripiano in alluminio con bicchiere conico
- Aluminium bathroom shelf with conical tumbler
- Tablette en aluminium avec gobelet conique
- Estante con repisa en aluminio, con vaso cónico

.XX FINISH







ART.	A	B	C
4CA.483.000N .xx	115*	123*	46*

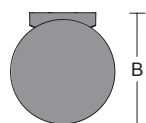
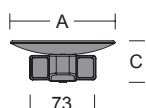

■ Polyamide 6

- Mensola con portasapone
- Shelf with soap dish
- Tablette avec porte-savon
- Estante con jabonera

.XX FINISH



ART.	A	B	C
4CA.483.00BN .xx	80*	105*	131*

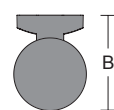
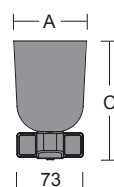

■ Polyamide 6

- Mensola con bicchiere
- Shelf with tumbler
- Tablette avec gobelet
- Estante con vaso



ART.	A	B	C
4CA.456.0000 .xx	80*	105*	173*

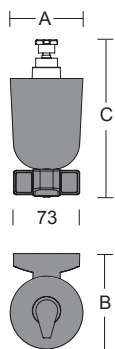

■ Polyamide 6

- Mensola con dispenser sapone
- Shelf with soap dispenser
- Tablette avec distributeur de savon
- Estante con dispensador de jabón (It 0,4)

.XX FINISH



ART.	A	B	C
4CA.486.000C .xx	98*	114*	438*

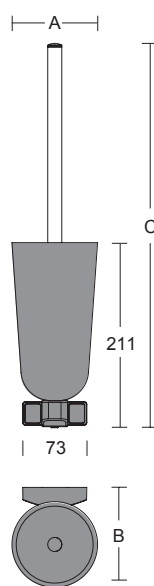

□ Anodized Aluminum  
■ Polyamide 6

- Portascopino ad imbocco conico
- Conical toilet brush set
- Ensemble brosse WC conique
- Escobillero cónico



ART. A  
4CN.486.000D .xx 555

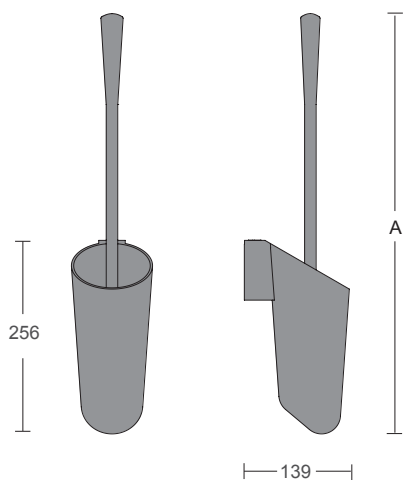

■ Polyamide 6

- Portascopino conico con attacco a muro integrato
- Conical toilet brush set with integrated wall fixing
- Ensemble brosse WC conique avec fixation murale intégrée
- Escobillero cónico con fijación en pared integrada

.XX FINISH



ART. A B  
4CA.481.0000 .xx 155\* 80

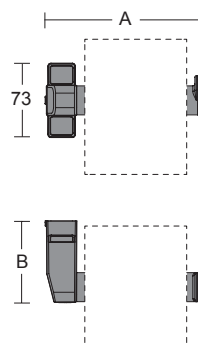

■ Polyamide 6

- Portarotolo a muro
- Wall toilet roll holder
- Porte-papier murale
- Portarollo de pared



ART.	A	B
4CA.481.00RL .xx	270*	80*

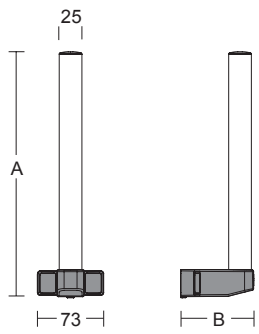

□ Anodized Aluminum  
■ Polyamide 6

- Portarotolo di riserva
- Spare toilet roll holder
- Porte-papier de réserve
- Portarrollos de reserva

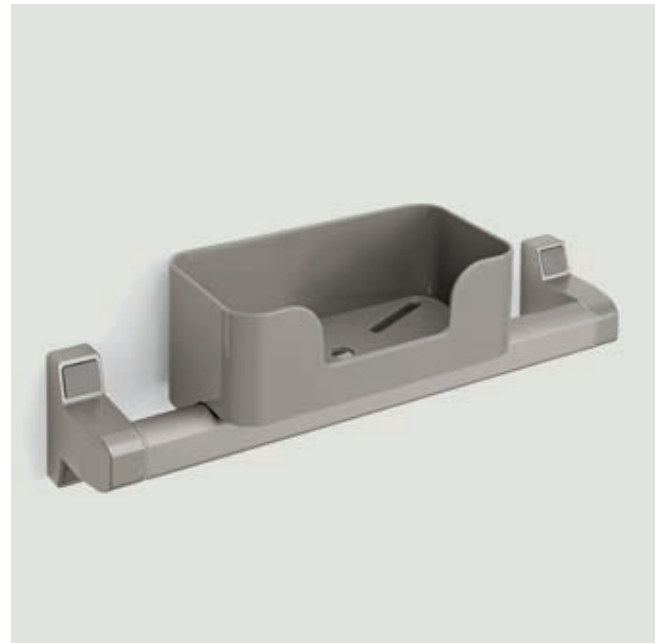

ART.	A	B	C
4CA.492.000B .xx	210*	105*	103*

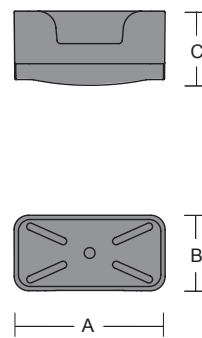

■ Polyamide 6

- Mensola applicabile su supporto orizzontale
- Shelf to be integrated to horizontal support
- Tablette accrochable à la barre d'appui horizontale
- Estante aplicable a asidero horizontal

.XX FINISH





ART.	A	B
4CA.489.000N .xx	370 (400)*	80*
4CA.489.00AN .xx	470 (500)*	80*
4CA.489.00BN .xx	570 (600)*	80*
4CA.489.00CN .xx	770 (800)*	80*
4CA.489.999N .xx	80*	80*

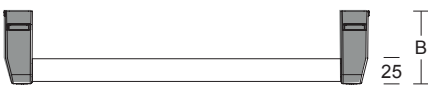
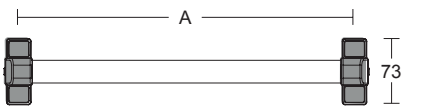

□ Anodized Aluminum  
■ Polyamide 6

- Portasciugamani
- Towel holder
- Porte-serviette
- Toallero

.XX FINISH



ART.	A	B
4CN.488.000P .xx	∅ 52	47*

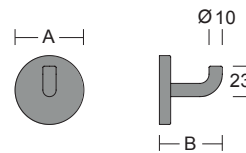

■ Polyamide 6

- Gancio appendiabiti piccolo
- Small cloth hook
- Patère petite
- Percha pequeña



ART.	A	B
4CN.488.000D .xx	Ø 55	40*

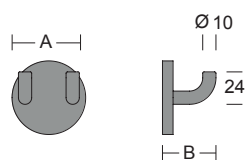

■ Polyamide 6

- Gancio appendiabiti doppio
- Double cloth hook
- Patère double
- Percha doble

.XX FINISH



ART.	A	B
5CN.562.0000 .xx	Ø 53	75*

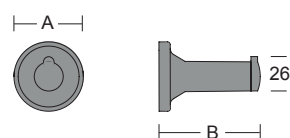

■ Polyamide 6

- Appendiabiti fermaporta
- Door-stop cloth hook
- Patère-butoir
- Tope-percha



ART.  
4CA.0RC.0000.00

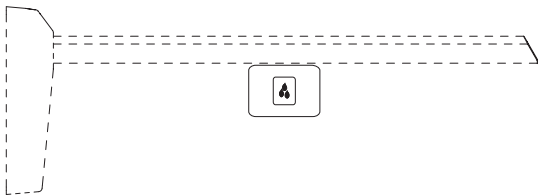

- Radiocomando per sistema elettronico di suono di emergenza e/o scarico dell'acqua WC
- Remote control for automatic WC-flushing system and/or emergency call
- Radiocommande pour système électronique d'évacuation de l'eau du WC et/ou appel d'urgence
- Control remoto electrónico para llamada de emergencia y/o la descarga de agua del WC



ART.  
4CA.0RC.002C.00

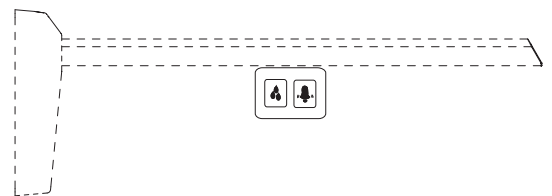

- Radiocomando per sistema elettronico di suono di emergenza e scarico dell'acqua WC
- Remote control for automatic WC-flushing system and emergency call
- Radiocommande pour système électronique d'évacuation de l'eau du WC et appel d'urgence
- Control remoto electrónico para llamada de emergencia y la descarga de agua del WC



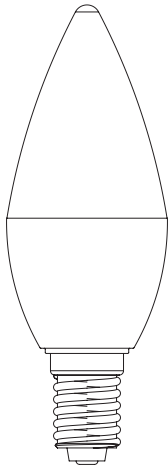

ART.  
4CN.407.00LT.00

- Lampadina LED di classe energetica A+
- Light LED bulb energy class A+
- Ampoule LED de classe énergétique A+
- Bombilla LED de eficiencia energética A+

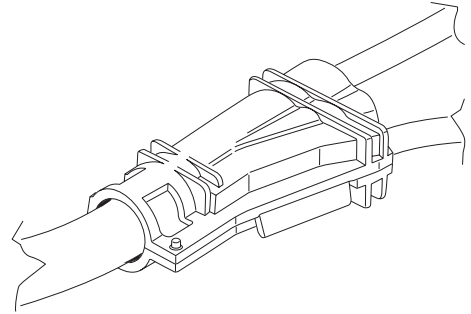

ART.  
4CN.0IP.0068.00

- Giunzione rapida per cavi elettrici
- Quick junction for electric cables
- Jonction rapide pour cables électriques
- Kit conector para cables eléctricos



ART.                    A  
4CA.486.00SR .xx    380\*

- Scopino di riserva con impugnatura
- Spare toilet brush with handle
- Brosse WC de réserve avec manche
- Escobilla de reserva con mango

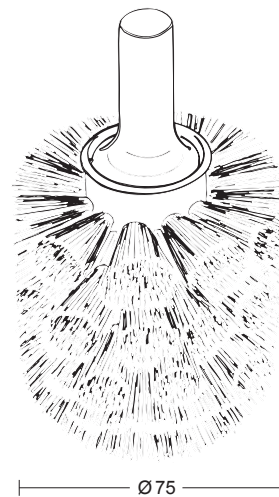

ART.  
4CA.486.000B.00

- Scopino di riserva per art. 4CN.486.000C
- Spare toilet brush head for art. 4CN.486.000C
- Tête brosse WC de réserve pour art. 4CN.486.000C
- Cabezal de escobilla de reserva para escobillero para art. 4CN.486.000C

.XX FINISH





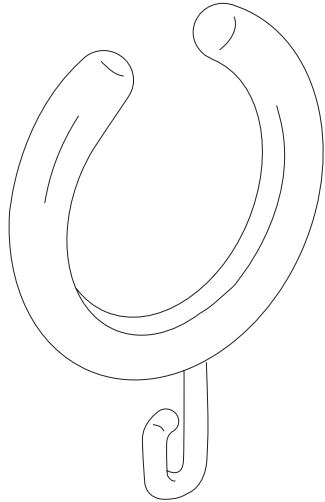

ART.  
4CN.0AN.0002 .xx

- Anello reggitenda
- Shower curtain ring
- Anneau pour rideau de douche
- Anillas para cortina

PROGRAMMA PBA WF

PATENT PENDING ITALY 102019000013932  
PATENT DEUTCHLAND 202020104488.5

P B A  
P A T E N T E D  
S Y S T E M

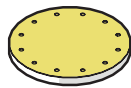
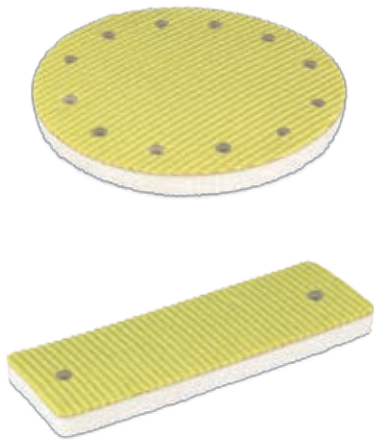

ART.  
4CN.0VM.WF40.00

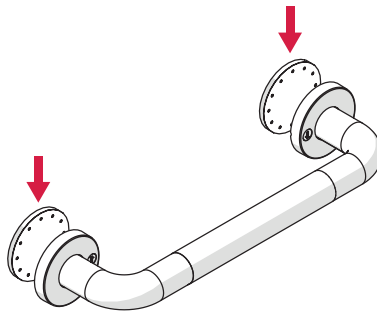

Articles with fixing rose



ART.  
4CN.0VM.WF41.00

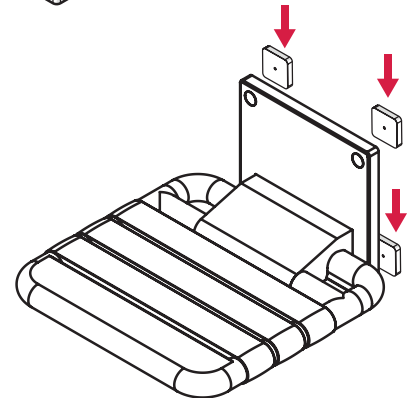

Shower seat with plate and lift-up support



ART.  
4CN.0VM.WF47.00

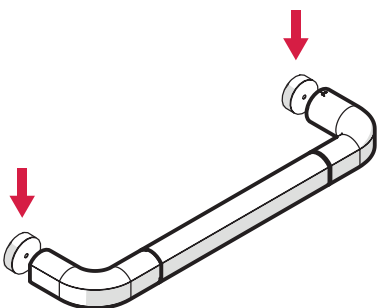

Safety support CAP and ART

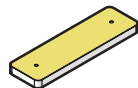

ART.  
4CN.0VM.WF48.00

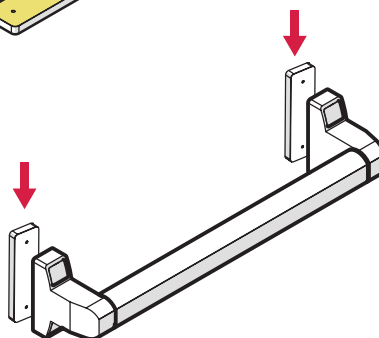

Safety support and accessories 400-ALU

IT

EN

FR

ES

## FINITURA

## FINISH

## FINITION

## ACABADO

400-NY  
400-HR-NY

NYLON

.A1 = Bianco Plus .07 = Grigio  
.01 = Bianco .09 = Rosso  
.02 = Biscotto .10 = Nero  
.03 = Giallo Pastello .17 = Antracite  
.04 = Giallo  
.05 = Blu Pastello

NYLON

.A1 = White Plus .07 = Grey  
.01 = White .09 = Red  
.02 = Biscuit .10 = Black  
.03 = Light yellow .17 = Anthracite  
.04 = Yellow  
.05 = Light blue

NYLON

.A1 = Blanc Plus .07 = Gris  
.01 = Blanc .09 = Rouge  
.02 = Biscuit .10 = Noir  
.03 = Jaune pastel .17 = Anthracite  
.04 = Jaune  
.05 = Bleu Pastel

NYLON

.A1 = Blanco Plus .07 = Gris  
.01 = Blanco .09 = Rojo  
.02 = Beige .10 = Negro  
.03 = Amarillo Pastel .17 = Antracita  
.04 = Amarillo  
.05 = Azul Pastel



A1



01



02



03



04



05



07



09



10



17

LRV

87

76

65

27

9

5

400-ALU

.70

TUBO

Alluminio anodizzato bronzo chiaro  
ACCESSORI  
Nylon grigio  
SUPPORTI E CURVE  
Lega verniciata grigio metallizzato

.70

RAIL

Aluminium anodized light bronze  
ACCESSORIES  
Nylon grey  
SUPPORTS AND BENDS  
Powder-coated alloy metallic grey

.70

TUBE

Aluminium anodisé bronze clair  
ACCESSOIRES  
Nylon gris  
SUPPORTS ET COUDES  
Alliage laqué gris métallisé

.70

TUBO

Aluminio anodizado bronce claro  
ACCESORIOS  
Nylon gris  
SOPORTES Y CURVAS  
Lacado gris metalizado



70



71

.71

RAIL

Aluminium anodized silver  
ACCESSORIES  
Nylon white  
SUPPORTS AND BENDS  
Powder-coated alloy white

.71

TUBE

Aluminium anodisé argent  
ACCESSOIRES  
Nylon blanc  
SUPPORTS ET COUDES  
Alliage laqué blanc

.71

TUBO

Aluminio anodizado  
ACCESORIOS  
Nylon blanco  
SOPORTES Y CURVAS  
Lacado blanco

CAP

ALLUMINIO VERNICIATO

.30 = Bianco  
.24 = Grigio

Colori a richiesta:  
lotti minimi da concordare



30



24

COATED ALUMINIUM

.30 = White  
.24 = Grey

Colours on demand:  
minimum lot to be agreed

ALUMINIUM PEINT

.30 = Blanc  
.24 = Gris

Couleurs sur demande:  
lots minimum à convenir

ALUMINIO PINTADO

.30 = Blanco  
.24 = Gris

Colores a petición:  
Lotes mínimos a convenir

ART

.75

TUBO

Alluminio anodizzato Antracite  
Elevata resistenza alla corrosione  
ACCESSORI  
Nylon Antracite  
SUPPORTI E CURVE  
Lega verniciata Antracite

.75

RAIL

Aluminium anodized Anthracite  
High corrosion resistance  
ACCESSORIES  
Nylon Anthracite  
SUPPORTS AND BENDS  
Powder-coated alloy Anthracite

.75

TUBE

Aluminium anodisé Anthracite  
Haute résistance à la corrosion  
ACCESSOIRES  
Nylon Anthracite  
SUPPORTS ET COUDES  
Alliage laqué Anthracite

.75

TUBO

Aluminio anodizado Antracita  
Alta resistencia a la corrosión  
ACCESORIOS  
Nylon Antracita  
SOPORTES Y CURVAS  
Lacado Antracita



75



17

.17

ACCESSORIES

Nylon Anthracite

.17

ACCESSOIRES

Nylon Anthracite

.17

ACCESORIOS

Nylon Antracita



ABRASION  
RESISTANCE  
TEST

400-SS  
400-HR-SSACCIAO INOX  
AISI 316L

.44 = Satinato  
.43 = Lucido

STAINLESS STEEL  
AISI 316L

.44 = Satined  
.43 = Bright

ACIER INOXIDABLE  
AISI 316L

.44 = Satiné  
.43 = Poli

ACERO INOXIDABLE  
AISI 316L

.44 = Mate  
.43 = Brillo

## IT

**ART.** Codice articolo  
 A richiesta  
 Ø Diametro  
 α Angolo  
 ◆ Verso: .1 Destro - .2 Sinistro



## STRUTTURA CODICI ARTICOLI PBA:



- \* Misura di massimo ingombro
- Peso di massimo utilizzo
- Certificato TÜV
- Conformità CE
- Non idoneo per seggiolini agganciabili
- Adipose

## EN

**ART.** Article code  
 Pls call  
 Ø Diameter  
 α Angle  
 ◆ Side: .1 Right - .2 Left

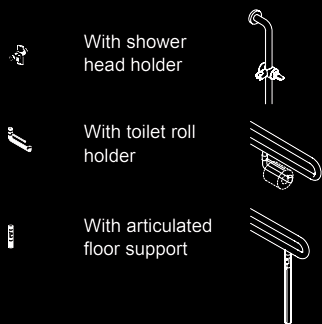

## STRUCTURE OF PBA ARTICLE CODES:



- \* Maximum overall dimension
- Maximum load
- TÜV Certificate
- CE Certificate
- Not suitable for suspended shower seat
- Adipose

## FR

**ART.** Code article  
 A la demande  
 Ø Diamètre  
 α Angle  
 ◆ Sens: .1 Droite - .2 Gauche

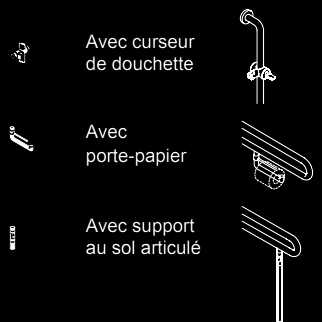

## STRUCTURE CODES DES ARTICLES PBA:

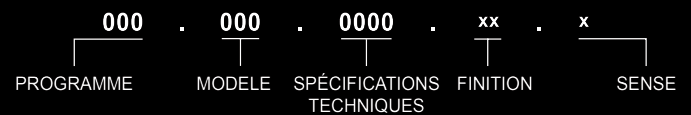

- \* Encombrement maximum
- Poids maximum d'utilisation
- Certificat TÜV
- Conformité CE
- Ne peut pas être utilisé avec un siège à suspendre
- Adipose

## ES

**ART.** Código artículo  
 Bajo pedido  
 Ø Diámetro  
 α Angulo  
 ◆ Lado: .1 Derecha - .2 Izquierda



## ESTRUCTURA CÓDIGOS DE ARTICULOS PBA:



- \* Tamanos máximos
- Peso máximo de utilizo
- Certificación TÜV
- Conformidad CE
- No apto para asiento para colgar
- Adipose

CERTIFICATO TÜV - TÜV CERTIFICATE  
CERTIFICAT TÜV - CERTIFICACIÓN TÜV



Certificate N° : Z1 029615 0019 Rev. 00

CONFORMITÀ CE - CE CONFORMITY  
CONFORMITÉ CE - CONFORMIDAD CE



Directive 93/42/CEE  
Directive 73/23/CEE  
(Modified by the directive 93/68/CEE)

TEST CITOTOSSICITÀ - CITOTOXICITY TEST  
TEST DE CYTOTOXICITÉ  
PRUEBA DE CITOTOXICIDAD

Cytotoxicity test to DIN EN ISO 10993-5

MATERIALI - MATERIALS - MATÉRIAUX - MATERIALES

ALUMINUM EN-AW 6060

La lega di alluminio 6060 è una lega a media resistenza con un livello leggermente più basso rispetto alla lega 6005A. Ha un'ottima resistenza alla corrosione, ottima saldabilità e buona resistenza alle basse temperature. È comunemente usata per realizzare elementi anche con forma complessa e risulta molto buona nei processi di anodizzazione.

The aluminum 6060 alloy has an excellent resistance to corrosion, to low temperatures and allows quality weldings. In the design world it is commonly used to create components with complex shapes allowing excellent quality results compared to other alloys for anodizing treatments.

L'alliage d'aluminium 6060 est un alliage pouvant être traité thermiquement de résistance moyenne, avec une résistance légèrement inférieure à l'alliage 6005A. Il présente une très bonne résistance à la corrosion, une très bonne soudabilité et une bonne formabilité à froid. Il est couramment utilisé pour les sections complexes et présente une très bonne réponse au processus d'anodisation.

La aleación de aluminio 6060 es una aleación que se puede tratar con calor de resistencia media, ligeramente inferior a 6005A. Tiene muy buena resistencia a la corrosión, muy buena soldabilidad y buena conformabilidad en frío. Se usa comúnmente para cortes transversales complejos y tiene una respuesta de anodización muy buena.

Alloy	Forms	Characteristics - Properties	Applications
EN - AW 6060	• Extruded round rod/bar	• Very good corrosion resistance • Medium strength • Complex sections • Anodising quality	Architectural sections, frames, lightings, railing, ladders, furniture, fences, flooring

Alloy	Temper	Temper designation (EN 515)
EN - AW 6060	O	Annealed wrought alloys
	T4	Solution heat treated & natural aged
	T5	Cooled from an elevated temperature forming operation & artificially aged (precipitation hardened)
	T6	Solution heat treated & artificially aged (precipitation hardened) Press quenching required
	T64	Solution heat treated & artificially aged (precipitation hardened) Under aged to improve formability (bending temper)
T66	Cooled from an elevated temperature forming operation & artificially aged (precipitation hardened) to a higher level of mechanical properties through special control of manufacturing processes. Press quenching required.	

REGISTRAZIONE MODELLI - REGISTERED MODELS -  
MODÈLES ENREGISTRÉS - REGISTRACIÓN MODELOS

I modelli del Programma 400-ALU sono stati registrati con domanda di brevetto numero 002497834.

All Programma 400-ALU models are registered with application number 002497834.

Tous les modèles Programma 400-ALU ont été enregistrés avec la demande de brevet numéro 002497834.

Les modelos del Programma 400-ALU se registraron con solicitud de patente número 002497834.

PULIZIA - MAINTENANCE - NETTOYAGE - LIMPIEZA

Hydrochloric acid	Muriatic acid	Hydrofluoric acid	Chlorine water / Bleaching solution	Neutral PH

ELEMENTI COSTRUTTIVI - STRUCTURAL ELEMENTS -  
ELEMENTS CONSTRUCTIFS - ELEMENTOS CONSTRUCTIVOS



ALUMINUM COMPONENTS  
ARE COMPLETELY  
SEPARABLE FOR RECYCLE

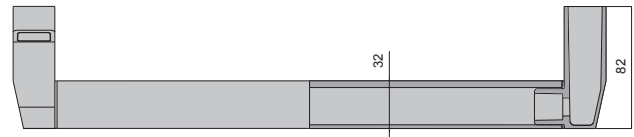

ELEMENTO RETTILINEO

Profilo in alluminio estruso lega EN AW-6060 anodizzato (HB=80MIN)

STRAIGHT ELEMENT

Extruded alloy EN AW-6060 aluminum tube anodized (HB=80MIN)

ÉLÉMENT RECTILIGNE

Tube en aluminium extrudé alliage EN AW-6060 anodisé (HB=80MIN)

ELEMENTO RECTILÍNEO

Perfil de aluminio extruido aleación EN AW-6060 anodizado (HB=80MIN)



ELEMENTO CURVO A 90°

Curva in alluminio pressofuso con cataforesi e verniciatura

90° BEND

Die-cast aluminum bend with cathaphoresis treatment and powder-coating

ÉLÉMENT CINTRÉ À 90°

Coude en aluminium moulé sous pression avec traitement de cathaphorèse et revêtement en poudre

ELEMENTO CURVO EN ÁNGULO DE 90°

Codo de aluminio moldeado a presión con cataforesi y recubrimiento en polvo

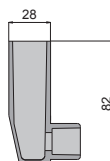
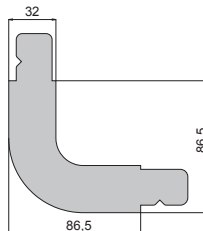

SUPPORTO A MURO

Supporto in lega di zinco (ZAMAK) con cataforesi e verniciatura

WALL SUPPORT

Zinc alloy support (ZAMAK) with cathaphoresis treatment and powder-coating

SUPPORT MURAL

Support en alliage de zinc (ZAMAK) avec traitement de cathaphorèse et revêtement en poudre

SOPORTE DE PARED

Soporte de aleación de zinc (ZAMAK) con cataforesi y recubrimiento en polvo

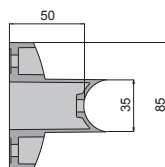

SUPPORTO DRITTO

Supporto in lega di zinco (ZAMAK) con cataforesi e verniciatura

STRAIGHT SUPPORT

Zinc alloy support (ZAMAK) with cathaphoresis treatment and powder-coating

SUPPORT DROIT

Support en alliage de zinc (ZAMAK) avec traitement de cathaphorèse et revêtement en poudre

SOPORTE RECTO

Soporte de aleación de zinc (ZAMAK) con cataforesi y recubrimiento en polvo

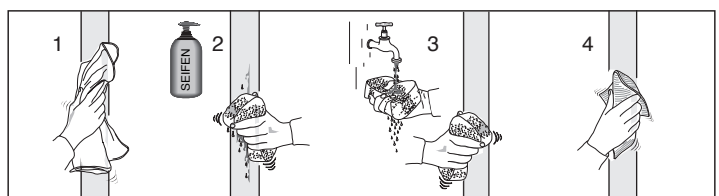

GUIDA AL PROGETTO - GUIDE TO THE PROJECT - DESCRIPTIF PROJET - GUÍA PARA EL PROYECTO

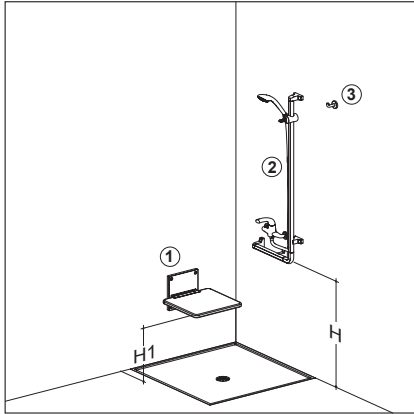

- ① 4CN.447.00CM    ② 4CA.22J.00LA    ③ 4CN.488.000P

(D)	DIN 18040-1 DIN 18040-2	H= 850	H1= 460/480
(I)	DM 236 14/06/1989	H= 800	H1= 450/500
(GB)	APPROVED DOCUMENT M	H= 680	H1= 480
(A)	Ö - NORM B 1600	H= 750/850	H1= 460/480
(F)	JORF n°195 (24/08/2006) Text 14 AFNOR NF P 99-611	H= 700/800	H1= 450/500
(CH)	SIA 500	H= 700/750	H1= 460

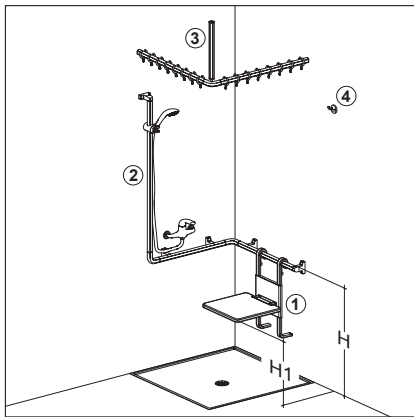

- ① 4CA.450.00CM    ② 4CA.24J.00LA    ③ 4CA.436.000B    ④ 4CN.488.000P

(D)	DIN 18040-1 (4CA.450.0CML) DIN 18040-2 (4CA.450.0CML)	H= 850	H1= 480
(I)	DM 236 14/06/1989 (4CA.450.00CM)	H= 800	H1= 500
(GB)	APPROVED DOCUMENT M	H= 680	H1= -
(A)	Ö - NORM B 1600 (4CA.450.00CM) (4CA.450.0CML)	H= 760/780 H= 830/850	H1= 460/480 H1= 460/480
(F)	JORF n°195 (24/08/2006) Text 14 AFNOR NF P 99-611 (4CA.450.00CM)	H= 750/800	H1= 450/500
(CH)	SIA 500	H= 700/750	H1= 460

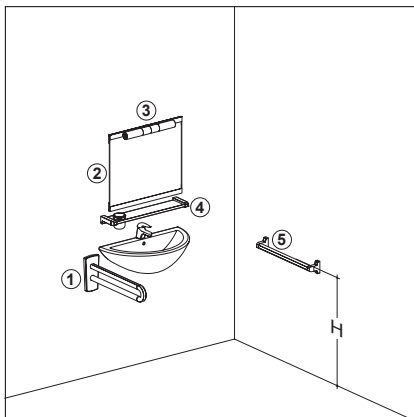

- ① 4CA.441.000P    ② 4CA.470.0000    ③ 4CN.407.0TUA    ④ 4CA.485.00AL    ⑤ 4CA.440.000A

(D)	DIN 18040-1 DIN 18040-2	H= 850
(I)	DM 236 14/06/1989	H= 800
(GB)	APPROVED DOCUMENT M	H= 680
(A)	Ö - NORM B 1600	H= 750
(F)	JORF n°195 (24/08/2006) Text 14 AFNOR NF P 99-611	H= 700/800
(CH)	SIA 500	H= 700/750

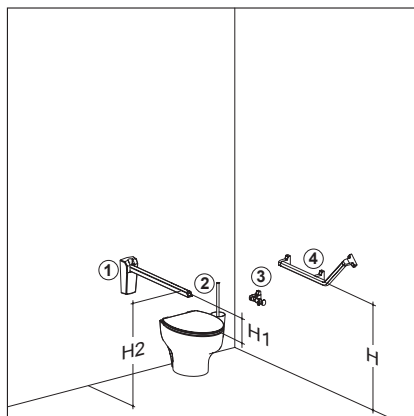

- ① 4CA.445.0000    ② 4CA.486.000C    ③ 4CA.481.0000    ④ 4CA.427.0000

(D)	DIN 18040-1 DIN 18040-2	H= 850	H1= 280	H2= 740/760
(I)	DM 236 14/06/1989	H= 800	H1= -	H2= 800
(GB)	APPROVED DOCUMENT M	H= 680	H1= -	H2= 680
(A)	Ö - NORM B 1600	H= 750	H1= -	H2= 750
(F)	JORF n°195 (24/08/2006) Text 14 AFNOR NF P 99-611	H= 700/800	H1= -	H2= 700/800
(CH)	SIA 500	H= 700/750	H1= 290	H2= 700/750

I riferimenti normativi sono riferiti alle quote di installazione da pavimento, non alle altre distanze e alle tipologie di bagno.  
 The norms references refer to installation measurements from the floor and not to other distances and types of bathroom.  
 Les références normatives se réfèrent aux mesures d'installation du sol et pas à d'autres distances et types de salle de bain.  
 Las referencias normativas se refieren a las medidas de montaje desde suelo y no a otras distancias y tipos de baño.

SISTEMI DI FISSAGGIO - FIXING MATERIAL - SISTÈMES DE FIXATION - SISTEMAS DE FIJACIÓN

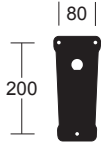

Art. 4CA.441.000P.xx  
Art. 4CA.441.00PL.xx  
Art. 4CA.441.0PLL.xx

Calcestruzzo e Pietra naturale - Concrete, Natural stone - Béton et Pierre naturelle - Hormigón y piedra natural

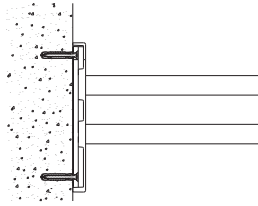

- KIT 4CN.0VM.0014.00**  
In dotazione - Included  
- Inclus - Includido:
- N°3 Fischer FU 10x60
  - N°3 6.3x80 INOX
  - N°3 bussole guida  
guide bushes  
douilles de guidage  
casquillo guía

Mattone pieno e Mattone calcareo - Solid brick, Sand-lime brick - Brique pleine et brique calcaire - Ladrillo macizo y silico calcáreo

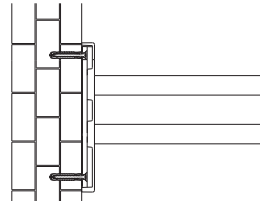

- KIT 4CN.0VM.0014.00**  
In dotazione - Included  
- Inclus - Includido:
- N°3 Fischer FU 10x60
  - N°3 6.3x80 INOX
  - N°3 bussole guida  
guide bushes  
douilles de guidage  
casquillo guía

Mattone forato - Hollow brick masonry - Brique creuse - Ladrillo hueco

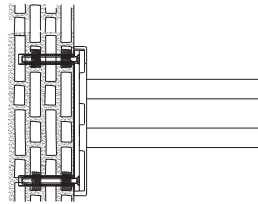

- KIT 4CN.0VM.0036.00**  
A pagamento - Extra  
- En supplément - De pago:
- N°3 Fischer FIS H 16x85 K
  - N°3 M8x25 INOX
  - N°3 FIS E 11x85 M8

Cartongesso e legno stratificato - Plasterboard, Wooden plate - Placoplâtre - Panneau de bois lamellé - Panel de cartón yeso y madera laminada

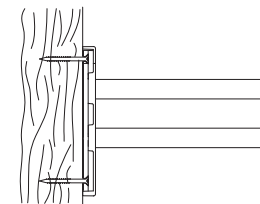

- KIT 4CN.0VM.0017.00**  
A pagamento - Extra  
- En supplément - De pago:
- N°3 8x80 INOX
  - N°3 bussole guida  
guide bushes  
douilles de guidage  
geleidmof  
casquillo guía

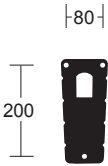

Art. 4CA.445.000T.xx  
4CA.45Y.000T.xx  
4CA.45K.000T.xx  
4CA.445.0000.xx  
4CA.45Y.0000.xx  
4CA.45K.0000.xx  
4CA.445.000L.xx  
4CA.45Y.000L.xx  
4CA.45K.000L.xx

Calcestruzzo e Pietra naturale - Concrete, Natural stone - Béton et Pierre naturelle - Hormigón y piedra natural

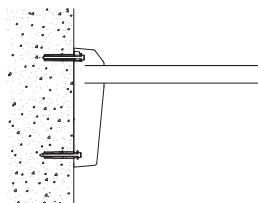

- KIT 4CN.0VM.0014.00**  
In dotazione - Included  
- Inclus - Includido:
- N°3 Fischer FU 10x60
  - N°3 6.3x80 INOX
  - N°3 bussole guida  
guide bushes  
douilles de guidage  
führungsbuchse  
casquillo guía

Mattone pieno e Mattone calcareo - Solid brick, Sand-lime brick - Brique pleine et brique calcaire - Ladrillo macizo y silico calcáreo

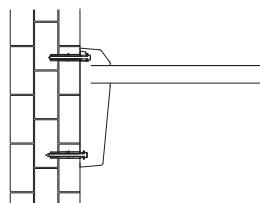

- KIT 4CN.0VM.0014.00**  
In dotazione - Included  
- Inclus - Includido:
- N°3 Fischer FU 10x60
  - N°3 6.3x80 INOX
  - N°3 bussole guida  
guide bushes  
douilles de guidage  
führungsbuchse  
casquillo guía

Mattone forato - Hollow brick masonry - Brique creuse - Ladrillo hueco

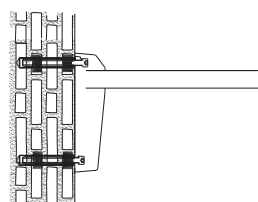

- KIT 4CN.0VM.0033.00**  
A pagamento - Extra  
- En supplément - De pago:
- N°3 Fischer FIS H 16x85 K
  - N°3 M8x30 INOX
  - N°3 FIS E 11x85 M8

Cartongesso e legno stratificato - Plasterboard, Wooden plate - Placoplâtre - Panneau de bois lamellé - Panel de cartón yeso y madera laminada

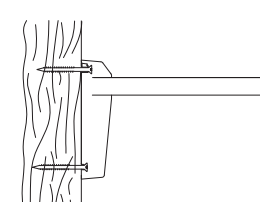

- KIT 4CN.0VM.0034.00**  
A pagamento - Extra  
- En supplément - De pago:
- N°3 8x90 INOX

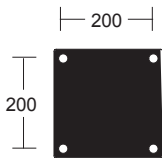

Art. 4CN.447.00CM.xx  
4CN.47K.00CM.xx

Calcestruzzo e Pietra naturale - Concrete, Natural stone - Béton et Pierre naturelle - Hormigón y piedra natural

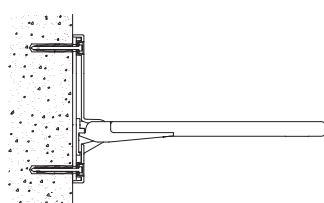

- KIT 4CN.0VM.0001.00**  
In dotazione - Included  
- Inclus - Includido:
- N°4 Fischer FU 10x60
  - N°4 6.3x80 INOX
  - N°4 bussole guida  
guide bushes  
douilles de guidage  
casquillo guía

Mattone pieno e Mattone calcareo - Solid brick, Sand-lime brick - Brique pleine et brique calcaire - Ladrillo macizo y silico calcáreo

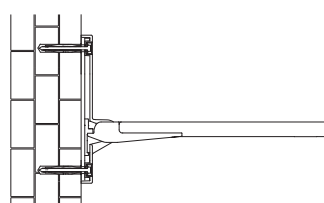

- KIT 4CN.0VM.0001.00**  
In dotazione - Included  
- Inclus - Includido:
- N°4 Fischer FU 10x60
  - N°4 6.3x80 INOX
  - N°4 bussole guida  
guide bushes  
douilles de guidage  
casquillo guía

Mattone forato - Hollow brick masonry - Brique creuse - Ladrillo hueco

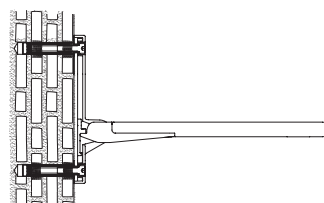

- KIT 4CN.0VM.0003.00**  
A pagamento - Extra  
- En supplément - De pago:
- N°4 Fischer FIP 20x85R
  - N°4 M10x30 INOX
  - N°4 FIP 14x80 M10i

Cartongesso e legno stratificato - Plasterboard, Wooden plate - Placoplâtre - Panneau de bois lamellé - Panel de cartón yeso y madera laminada

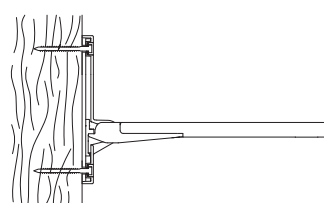

- KIT 4CN.0VM.0009.00**  
A pagamento - Extra  
- En supplément - De pago:
- N°4 8x90 INOX
  - N°4 bussole guida  
guide bushes  
douilles de guidage  
führungsbuchse  
casquillo guía

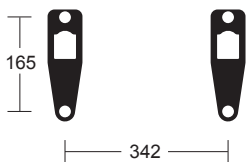

Art. 4CA.451.000B.xx



Ausili  
Disabled  
Accessories Barres  
de maintien  
Asideros

Calcestruzzo e Pietra naturale - Concrete, Natural stone - Béton et Pierre naturelle - Hormigón y piedra natural

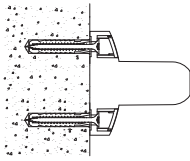

**KIT 4CN.VM.0030.00**  
In dotazione - Included  
- Inclus - Includido:

- N°2 Fischer SX10
- N°2 6x70 INOX
- N°2 bussola guida  
guide bushes  
douilles de guidage  
casquillo guía

Mattone pieno e Mattone calcareo - Solid brick, Sand-lime brick - Brique pleine et brique calcaire - Ladrillo macizo y sílico calcáreo

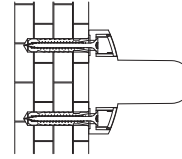

**KIT 4CN.VM.0030.00**  
In dotazione - Included  
- Inclus - Includido:

- N°2 Fischer SX10
- N°2 6x70 INOX
- N°2 bussola guida  
guide bushes  
douilles de guidage  
casquillo guía

Mattone forato - Hollow brick masonry - Brique creuse - Ladrillo hueco

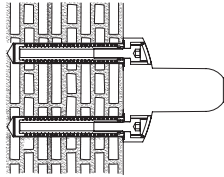

**KIT 4CN.0VM.0031.00**  
A pagamento - Extra -  
En supplément - De pago:

- N°2 Fischer FIS H 16X85 K
- N°2 M8X30 INOX
- N°2 FIS E 11X85 M8
- N°2 bussola guida  
guide bushes  
douilles de guidage  
casquillo guía

Cartongesso e legno stratificato - Plasterboard, Wooden plate - Placoplâtre - Panneau de bois lamellé - Panel de cartón yeso y madera laminada

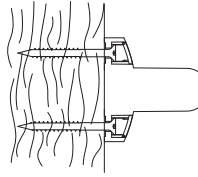

**KIT 4CN.0VM.0032.00**  
A pagamento - Extra -  
En supplément - De pago:

- N°2 8x80 INOX
- N°2 bussola guida  
guide bushes  
douilles de guidage  
casquillo guía

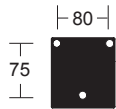

Art. 4CN.445.0CPM.00

Calcestruzzo e Pietra naturale - Concrete, Natural stone - Béton et Pierre naturelle - Hormigón y piedra natural



**KIT 4CN.0VM.0014.00**  
In dotazione - Included  
- Inclus - Includido:

- N°3 Fischer FU 10x60
- N°3 6,3x80
- N°3 bussola guida  
guide bushes  
douilles de guidage  
casquillo guía

Mattone pieno e Mattone calcareo - Solid brick, Sand-lime brick - Brique pleine et brique calcaire - Ladrillo macizo y sílico calcáreo



**KIT 4CN.0VM.0015.00**  
A pagamento - Extra - En  
supplément - De pago:

- N°3 Fischer FUR 10x80SS
- N°3 7x85

**KIT 4CN.0VM.0029.00 (INOX)**  
A pagamento - Extra - En  
supplément - De pago:

- N°3 Fischer FUR 10x80SS INOX
- N°3 7x85

Mattone forato - Hollow brick masonry - Brique creuse - Ladrillo hueco



**KIT 4CN.0VM.0016.00**  
A pagamento - Extra - En  
supplément - De pago:

- N°3 Fischer FIS H 20X85 K
- N°3 M10X30 INOX
- N°3 FIS E 15X85 M10

Cartongesso e legno stratificato - Plasterboard, Wooden plate - Placoplâtre - Panneau de bois lamellé - Panel de cartón yeso y madera laminada



**KIT 4CN.0VM.0017.00**  
A pagamento - Extra - En  
supplément - De pago:

- N°3 8x90
- N°3 bussola guida  
guide bushes  
douilles de guidage  
casquillo guía

**NOTA:** PER FISSAGGI SU ALTRI MATERIALI E PER LO SPESSORE MINIMO DEL LEGNO DA UTILIZZARE COME RINFORZO DEL CARTONGESSO, RIVOLGERSI ALL'UFFICIO TECNICO pba.  
**NOTE:** FOR FIXING ON OTHER MATERIALS AND FOR THE MINIMUM THICKNESS OF THE WOOD REINFORCEMENT FOR PLASTERBOARD, PLEASE CONTACT pba TECHNICAL DEPT.  
**REMARQUE:** POUR FIXATION SUR D'AUTRES MATÉRIAUX ET POUR L'ÉPAISSEUR MINIMUM DU BOIS À UTILISER COMME RENFORCEMENT DANS LE PLACOPLÂTRE, CONTACTEZ LE SERVICE TECHNIQUE pba.  
**NOTA:** PARA FIJAR EN OTROS MATERIALES Y PARA EL ESPESOR MÍNIMO DE LA MADERA QUE HAY QUE UTILIZAR COMO REFUERZO DEL PANEL DE CARTÓN YESO, CONTACTEN EL DEPARTAMENTO TÉCNICO pba.

Per le etichette energetiche degli apparecchi di illuminazione: [www.pba.it](http://www.pba.it)  
For the Energy Labels of the illumination instruments see our website: [www.pba.it](http://www.pba.it)  
Pour l'étiquette-énergie des nos appareils d'éclairage voir le site: [www.pba.it](http://www.pba.it)  
Para las etiquetas energéticas de los dispositivos de iluminación: [www.pba.it](http://www.pba.it)

